

## PRO-62 | ANNULAR CUTTER DRILLING MACHINE

The PRO-62 drill equipped with 19 mm (3/4") Weldon tool holder uses TCT and HSS annular cutters that cut only a groove at the periphery of the hole, leaving a solid core or slug at the center. Strong motor enables cutting capacity up to 65 mm (2-9/16") and depth of cut up to 75 mm (3"). Dual guide bars design empowers maintenance free rail guide system.

### Features and benefits:

- powerful motor with heavy duty 2-speed gearbox
- maintenance free rail guide system thanks to dual guide bars
- innovative smart magnet with reduced weight
- rigid design extends tool life
- Magnetic Field Shape Control (MFSC) provides maximum holding power on thin materials
- Magnetic Power Adhesion Control (MPAC) detects adhesive force of electromagnetic base and protects both the machine and the operator from work on too thin workpiece
- Energy Saving Base(ESB) uses only 50% of its power when motor is not running
- The motor stops automatically when the brushes are worn out (it is necessary to replace the brushes to restart the motor)
- milling with TCT or HSS cutters
- drilling with twist drills feat. Weldon shank
- large coolant container



Milling capacity up to 65 mm (2-9/16")



Max depth of cut up to 75 mm (3")

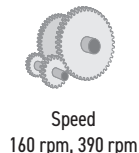
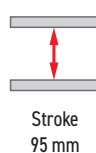
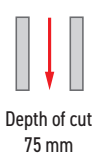

**PRO-62 TECHNICAL SPECIFICATION**

Motor Speeds (under load)	160 rpm (gear I) 390 rpm (gear II)
Power	1600 W
Weight	17 kg (37 lbs)
Max milling capacity	65 mm (2-9/16")
Stroke	95 mm (3-3/4")
Max depth of cut	75 mm (3")
Voltage	1~ 220-240 V, 50-60 Hz 1~ 110-120 V, 50-60 Hz
MFSC (Magnetic Field Shape Control)	yes
MPAC (Magnetic Power Adhesion Control)	yes
ESB (Energy Saving Base)	yes
Magnetic clamping force (surface with the thickness of 25 mm and roughness Ra = 1.25)	1122 kgf (11 000 N)
Magnet Base Dimensions	90 mm × 180 mm × 48 mm 3-9/16" x 7" x 1-7/8"
Min. Workpiece Thickness	8 mm (5/16")
Tool holder	19 mm (3/4") Weldon
Product Code 220-240 V, 50-60 Hz	WRT-0630-10-20-00-0
Product Code 110-120 V, 50-60 Hz	WRT-0630-10-10-00-0

**Dimensions:**

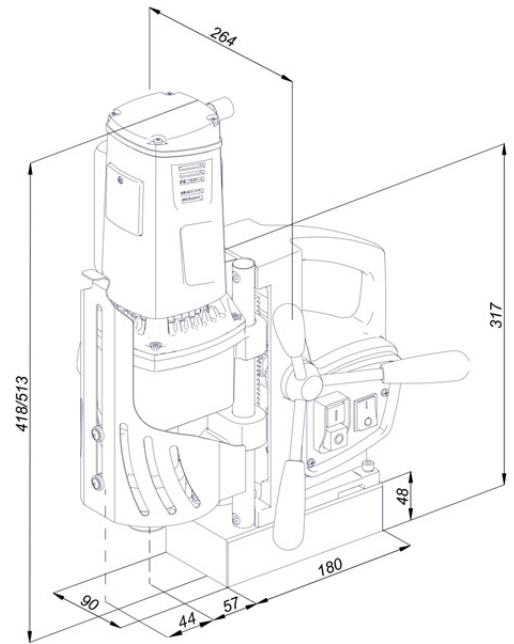

**Standard shipping set:**

- Drilling machine
- Plastic box
- Cooling system
- Handle (3 pcs)
- Safety strap
- 4 mm hex wrench with a handle
- Operator's Manual



**More optional accessories:**

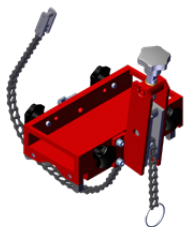

Pipe attachment DMP 251  
for pipes with diameters of  
80-250 mm (3-10")  
Product code: PDS-0110-03-00-01-0

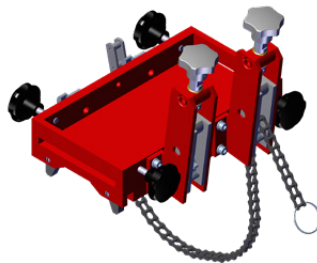

Pipe attachment DMP 501  
for pipes with diameters of  
150-500 mm (6-20")  
Product Code: PDS-0111-03-00-01-0



Pressure cooling system capacity of 2 liters  
Product Code: UKL-0440-16-00-00-0

All information is subject to change without notice. 23.03



**PROMOTECH FABRICATION MACHINES PVT LTD**

Corporate Office :  
C 8, DSIIDC Packaging Complex  
Kirti Nagar New Delhi - 110015

Mobile: +91 966 766 0304  
india@promotech.eu  
www.promotech-india.in

Your local dealer:

